

ASSEMBLY AND OPERATIONS INSTRUCTIONS

FOR

GIANT-TRUCK LOADER MODELS

1601-C - 1901-C

Your shipment of a Giant-Truck Loader should consist of the following parts:

- 1 - Power unit and blower housing.
- 1 - Exhaust stack and elbow.
- 1 - Intake hose and nozzle.
- 1 - Hardware kit.

THE FOLLOWING PARTS ARE OPTIONAL:

- 1 - Axle, wheels, draw bar and support jack.
- 1 - Spring loaded boom.
- 1 - Metal hose and square to round.

Inspect parts for any damage that might have occurred in shipping. If any is found, or any shortages noted, notify the transport carrier who delivered your machine as he is responsible for the damage and is the only one to make any adjustments. Before leaving our plant, all components were completely inspected. All manufacturing dimensions are held to close tolerances, and thus, you will have little difficulty in assembling your Giant Truck Loader if you follow these steps.

ENGINE INSTRUCTIONS: An engine manual is supplied with each shipment. This should be read carefully. Instructions on oil changes should be carefully noted to ensure maximum engine life.

We recommend that the engine be run at a fast idle for at least 1 hour. Following this, the engine should be retuned. A good check should include carburetor and timing adjustments.

The engine is warranted by the engine manufacturer. Please be certain to mail to them, the warrantee card, IMMEDIATELY. If any engine problems exist, please contact their nearest service center as only they can authorize any warrantee claims.

ASSEMBLY: The axle should be bolted to the lower portion of the blower housing in the most forward position in relation to the blower housing. This ensures optimum balance for operation. The draw bar, Ref. #19, is to be bolted onto the front of motor base. The support jack, Ref. #20, is bolted onto draw bar. Then the exhaust stack, Ref. #5, is bolted onto the blower housing. The exhaust elbow, Ref. #6, is bolted to the stack. Secure the square to round, Ref. #37, to metal hose, Ref. #23, and fasten to the end of the exhaust elbow. The boom should then be installed in the boom holder. This is done by sliding the vertical arm into the upper bracket and then dropping down into the lower bracket. The cuttrigger arm is next installed and fastened with a 1/2" bolt and lock nuts. The threaded support spring arm is fastened which completes this assembly.

HOSE ASSEMBLY AND POSITIONING: The hose is next installed and secured to the flange by means of a stainless steel hose clamp. Following this, the boom hose support band is slipped over the hose. This should be secured about 3 feet from the end of the hose. The pick up nozzle is next installed and fastened with a second hose clamp.

A chain connects the hose support band to the end of the boom. It is vitally important that this chain is adjusted correctly for ease of operation. In general, the chain should be so adjusted that the nozzle is approximately 12 inches off the ground.

The ultimate check to be certain this adjustment is correct takes place after the machine is running at operating speed. To make this check, speed up the engine. You should then be able to push the nozzle to the ground and pull it back up by using three fingers of one hand. If you cannot operate the nozzle accordingly, either the chain should be readjusted or the spring tension of the boom assembly, changed. A few minutes time in adjusting this correctly will ensure ease in operation.

DEBRIS BOXES: Your Giant-Truck Loader can be readily used in conjunction with a dump truck or garbage packer. The following are a few thoughts which we hope might be helpful in constructing these boxes.

To begin with, it is important to have an adequate screened section for allowing the tremendous volume of air that your Giant-Truck Loader gulps up each minute, to escape. As a matter of fact, we strongly recommend the entire top be covered with screening. One inch expanded mesh or 1/4 inch square wire makes an excellent screen. The theory behind this is quite simple. For example, if 10 square feet of exhaust section would produce a 100 miles per hour exhaust velocity, this would be cut down to a 10 miles per hour exhaust velocity if the opening was increased to 100 square feet.

If a dump truck is used, the collection box is generally fabricated out of ply-wood and angle iron. Quite often, a 3 inch angle iron frame is first fabricated. The sides are lined with 3/4 inch thick exterior type plywood. Do not use any thinner plywood as the internal pressure is apt to blow the sides out.

A frame is made for the top which is next covered with metal screening. The dump truck door should be removed. A door should then be fabricated which is hinged at the top. This also can be fabricated from angle iron and ply-wood.

Giant-Vac Leaf Loaders produce a tremendous amount of air. It is for this reason we recommend the following.

If the leaves are dry - in most cases we recommend running the leaf loader at approximately half throttle. This will help reduce small particles of debris from escaping through the exhaust screen. When the leaves are wet or partially frozen, we recommend running the machine at full throttle.

SAFETY AND OPERATING INSTRUCTIONS  
FOR GIANT-VAC LEAF LOADERS

CAUTION  
ROTATING PARTS

1. BEFORE OPERATING READ OPERATORS MANUAL FOR OPERATING AND SAFETY INSTRUCTIONS.
2. DO NOT OPERATE WITH ANY GUARDS OR COMPONENT PARTS REMOVED FROM UNIT.
3. BEFORE MAKING ANY ADJUSTMENTS OR REPAIRS, STOP ENGINE AND REMOVE SPARK PLUG WIRES ON GAS ENGINES - ON DIESEL ENGINE BE SURE ENGINE KILL SWITCH IS ACTIVATED.
4. WHILE IN OPERATION KEEP ALL PARTS OF BODY AWAY FROM INTAKE AND EXHAUST SECTIONS.
5. WHEN OPERATING MACHINE KEEP PEOPLE AND PETS A SAFE DISTANCE AWAY.

TRAINING:

1. Regard your Giant-Vac Leaf Loader as a piece of power equipment and teach this regard to all who operate this unit.
2. Never allow children or young teen-agers to operate the Giant-Vac Leaf Loader.
3. Be sure you know how to stop the engine at a **MOMENT'S NOTICE**.
4. Instruct children to keep away from the area of operation at all times.

PREPARATION:

1. Before starting operation, clear the entire work area of all debris that could catch on or be thrown by the Giant-Vac Leaf Loader.
2. Unless there is very good artificial light, use only during the daylight hours.
3. Fill the Giant-Vac Leaf Loader fuel tank outdoors. Avoid spilling fuel and do not fill the tank while engine is running or while you are smoking.

OPERATION:

1. Do not operate with any guards or component parts removed from unit.
2. Before making any adjustments or repairs, stop engine and remove the spark plug wire on gas engines - on diesel engines be sure engine kill switch is activated.
3. While in operation, keep all parts of body away from intake and exhaust sections.
4. When operating machine, keep people and pets a safe distance away.
5. Follow the engine manufacturer's recommendations for safe operation.
6. Use caution in selecting your cleaning pattern.
7. The Giant-Vac Leaf Loader is designed to be used in conjunction with a dump truck that has a receiver box installed. Be sure the receiver box is of adequate construction to withstand the high velocity and force of the incoming debris. **NEVER** run or operate your Giant-Vac Leaf Loader unless it is completely connected to a receiver box and the intake hose is installed.

8. Never allow another person to ride or stand on the Giant-Vac Leaf Loader. Never allow another person to ride, sit or stand on the towing vehicle other than in the drivers cab of the towing vehicle.

9. Make sure the operator of the towing vehicle has the operator of the Giant-Vac Leaf Loader in full view at all times. Also when operating a Giant-Vac Leaf Loader, instruct the hose operator to stay behind or to the side of the Leaf Loader - never in front.

## WARRANTY

GIANT-VAC MFG. COMPANY INCORPORATED, here-in-after called Giant-Vac, warrants each new Giant-Vac to the original retail purchaser of new Giant-Vac equipment to be free from manufacturing defects in normal service for a period of 90 days, unless it is used for rental purposes which limits the warranty to 30 days. This warranty does not apply to engines, tires or other parts that are manufactured and warranted by the manufacturer. Items such as bags, grass catchers, hoses and blades are not warranted, as these are considered expendable items. This warranty does not include equipment failures due to normal wear.

An obligation under this warranty is expressly limited to the replacement or repair at an authorized servicing Giant-Vac dealer, or at a point designated by us, of such parts or parts as such appear to us to have been defective. All defective parts have to be returned freight prepaid before credit is issued.

We shall not be liable for transportation charges in connection with the replacement or repair of defective parts.

This warranty does not apply to a Giant-Vac upon which repairs or alterations have been made by other except with our prior written approval.

We shall not be liable for consequential damages or contingent liabilities nor for the fitness of any Giant-Vac for any particular purpose.

We make no other express, implied or statutory warranty, nor is anyone authorized to make any in our behalf.

GIANT-TRUCK LOADERS

<u>REF.</u> <u>NO.</u>	<u>PART</u> <u>NO.</u>	<u>DESCRIPTION</u>	<u>1601-C</u>	<u>1901-C</u>
1	10032	Motor base frame	1	
1	10104	Motor base frame		1
2	10034	Blower housing	1	
2	10035	Blower housing		1
3	21531	Impeller with bolt and key	1	
3	21517	Impeller with bolt and key		1
4	20154	Intake flange	1	
4	20155	Intake flange		1
5	24535	Exhaust stack w/boom holder	1	1
6	24536	Exhaust elbow	1	1
7	24537	8 inch square to round exhaust	1	1
8	31114	Hex head bolt 3/8 x 1"	12	12
9	31115	Lockwasher 3/8"	24	24
10	31116	Nut 3/8"	24	24
11	31117	Hex head bolt 1/2 x 4-1/2"	4	4
12	31118	Nut 1/2"	12	12
13	31119	Flat washer	17	17
14	31120	Bolt 3/8 x 1-1/2"	4	4
15	31121	Lockwasher 1/2"	12	12
16	33037	Wheel 480 x 4.8 16" O.D.	2	2
16-a	33126	Wheel (optional) F 78 x 15 auto.	2	2
17	33046	Axle less hub	1	
17-a	33127	Axle w/hub for F 78 x 15	1	
17	33047	Axle less hub		1
17-b	33128	Axle w/hub for F 78 x 15		1
18	33038	Hub and bearing 4 hole bolt	2	2
18-a	33058	4 bolt hub only	1	1
18-b	33056	Bearing only	1	1
18-c	33055	Dust cap only	1	1
18-d	33057	Seal only	1	1
18-e	31156	Axle nut only	8	8
19	38003	Draw bar	1	1
20	33040	Support jack	1	1
21	34007	Intake hose 10" x 10'	1	
21	34019	Intake hose 12" x 10'		1
22	34016	Hose clamp 10"	2	
22	34020	Hose clamp 12"		2
23	34021	Metal exhaust hose 8" x 5'	1	1
24	20150	Intake nozzle 10"	1	
24	20156	Intake nozzle 12"		1
25	40119	Battery box	1	1
26	40113	Fuel tank		1
27	31153	Fuel tank straps		1
28	40114	Fuel tank cap		1
	39036	16HP Kohler Engine Electric	1	
	39037	20HP Kohler Engine		1
	39020	Battery	1	1

POWER UNIT

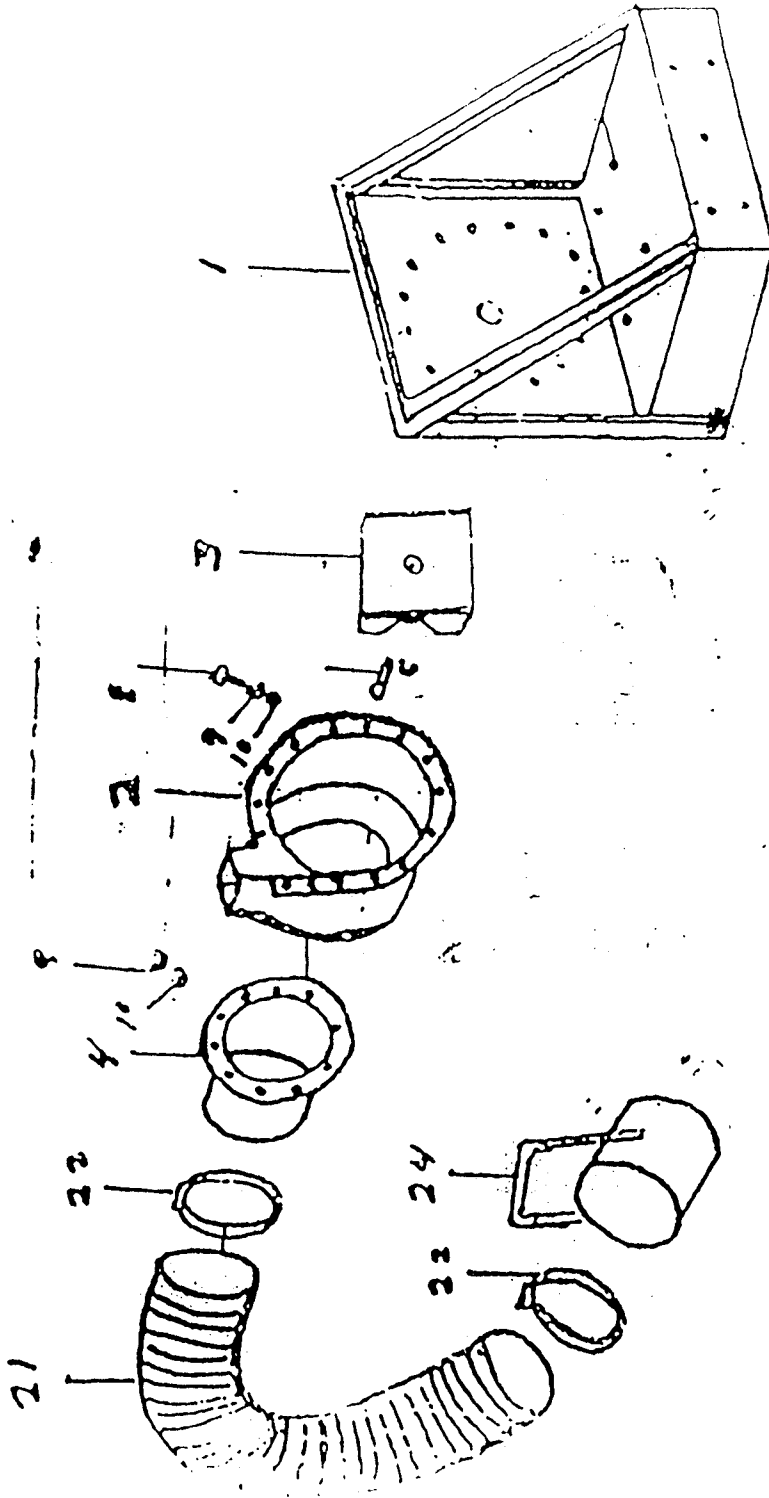

FOR MODEL 1001 - 1601 - 1901 - 2001

TRAILER MOUNT

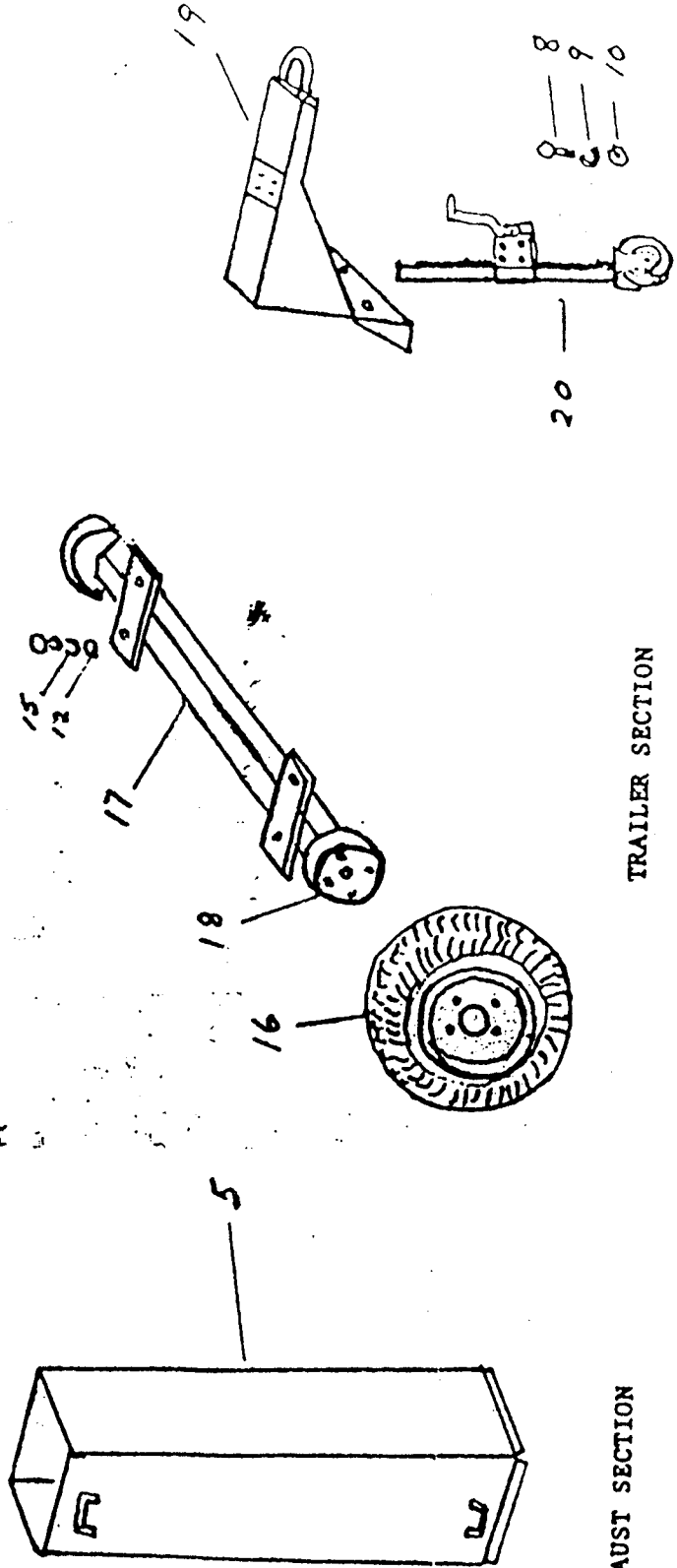
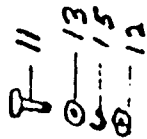
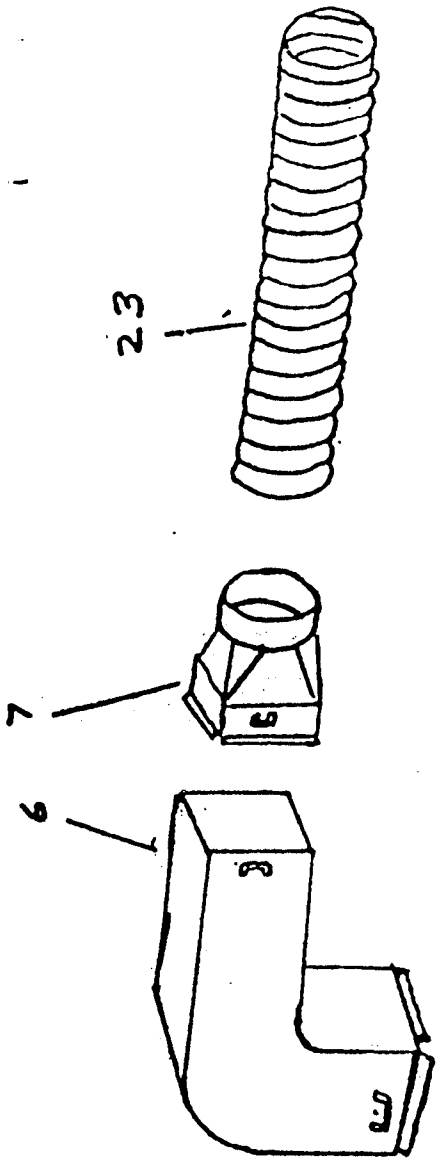

EXHAUST SECTION

TRAILER SECTION



PARTS LIST NO. 5722

HOSE SUPPORT BOOM  
FOR  
GIANT-TRUCK LOADERS

REF. NO.	PART NO.	DESCRIPTION	1001-C	2001-C	3001-C	6500	6800	9800
			1601-C			6600		
1	40107	Boom Vertical Member	1	1	1	1	1	1
2	40106	Boom Horizontal Member	1	1	1	1	1	1
3	40108	Threaded Spring Guide	1	1	1	1	1	1
4	31330	Hex nut 5/8"	1	1	1	1	1	1
5	31331	Flat washer 5/8"	2	2	2	2	2	2
6	31332	Boom Coil spring	2	2	2	2	2	2
7	31333	Hex head bolt 1/2" x 3"	1	1	1	1	1	1
8	31334	Jam nut 1/2"	1	1	1	1	1	1
9	31335	Hex head bolt 1/2" x 4"	4	4	4	4	4	4
10	31140	Chain	1	1	1	1	1	1
11	40109	Hose support band	1	1	1	1	1	1
11	40110	Hose support band		1				
11	40111	Hose support band			1			
11	40112	Hose support band						
12	31141	Hex bolt 5/16" x 3"		1	1	1	1	1
13	31142	Hex head nut 5/16"	1	1	1	1	1	1
14	31143	Flat washers 5/16"	2	2	2	2	2	2

May 3, 1984

# HOSE SUPPORT BOOM

