

GIANT-VAC®

ASSEMBLY INSTRUCTIONS
OPERATOR'S MANUAL
PARTS LIST

29hp Series ***Truck Loader***



Actual product differs from product pictured above

Model No.	Description
3800019	TLP29201BVG

Manual No. 3100016
Revision: - 01/01/08

1 preliminaries

Congratulations!

You have just purchased one of the finest pieces of outdoor power equipment on the market today. If properly cared for, your new Giant-Vac truck loader will provide years of dependable service. Please read and follow this instruction manual carefully in order to get the most out of your new equipment.

As you carefully uncrate your unit, you will find the following items:

- 1 Pallet containing:
 - 1 Power Unit (with trailer frame and installed support jack and support leg if CHW unit)
 - 1 Set of Fenders (CHW Units only)
 - 1 Package containing tail-lamps and wiring harness
 - 1 Package containing fender and wiring hardware
- 1 Hose/Parts Accessory Kit containing:
 - 1 Discharge Stack
 - 1 Discharge Elbow
 - 1 8" dia. x 5' Metal Discharge Hose
 - 1 8" Squeeze Ring
 - 1 10' length of Intake Hose (12" for 19-2501 units)
 - 1 Intake Nozzle (12" for 19-2501 units)
 - 1 Package containing Assembly Hardware and two Hose Clamps (12" for 19-2501 units)
 - 1 Package containing operating manuals and warranty registration

Each product leaves our factory in excellent condition; occasionally, however, some damage may occur during shipment. If any such damage is found upon initial inspection, *immediately* notify the transport carrier who delivered your machine, as they are solely responsible for such damage, as well as any subsequent adjustments necessary.

Your new loader requires very little assembly. Simply follow the instructions contained within this manual to begin enjoying the benefits of your new unit.

CALIFORNIA PROPOSITION 65 WARNING

Gasoline and Diesel engine exhaust and some of its constituents are known to the State of California to cause cancer, birth defects and other reproductive harm.

As an owner of off-road gasoline or diesel engine equipment and/or as an employer, you also may have an obligation under the California Occupational Safety and Health Act or under Proposition 65 to warn persons exposed to gas and diesel engine exhaust and/or other Proposition 65 chemicals in and around your workplace. See California Health and Safety Code section 25249.5, Title 22 of the California Code of Regulations at Section 1200 *et seq.*, and Title 8 of the California Code of Regulations Section 5194.

R0608.1

2 *safety rules regarding outdoor power equipment*

PLEASE READ THE FOLLOWING BEFORE ASSEMBLING OR OPERATING UNIT

TRAINING

- Read, understand, and follow all instructions in the manual and on the unit before starting. If the operator(s) or mechanic(s) can not read English it is the owner's responsibility to explain this material to them.
- Become familiar with the safe operation of the equipment, operator controls, and safety signs.
- All operators and mechanics should be trained. The owner is responsible for training the users.
- Only allow responsible adults, who are familiar with the instructions, to operate the unit.
- Never let children or untrained people operate or service the equipment. Local regulations may restrict the age of the operator.
- The owner/user can prevent and is responsible for accidents or injuries occurring to themselves, other people or property.

PREPARATION

- Evaluate the terrain to determine what accessories and attachments are needed to properly and safely perform the job. Use only accessories and attachments approved by the manufacturer.
- Wear appropriate clothing including safety shoes, safety glasses and ear protection. Long hair, loose clothing or jewelry may get tangled in moving parts.
- Inspect the area where the equipment is to be used and remove rocks or any other such objects which can damage the machine or the receiver box.
- Use extra care when handling gasoline and other fuels. They are flammable and vapors are explosive.
 - a) Use only an approved container.
 - b) Never remove fuel cap or add fuel with the engine running. Allow engine to cool before refueling. Do not smoke.
 - c) Never refuel or drain the machine indoors.
- Check that operator's presence controls, safety switches and shields are attached and functioning properly. Do not operate unless they are functioning properly.

OPERATION

- Never run an engine in an enclosed area.
- Operate only in the daylight or with good artificial light, keeping away from holes and hidden hazards.
- Be sure all components are securely in place and in good operating order before starting engine.
- Be sure of your footing while using equipment, especially when backing up. Walk, don't run.
- Do not operate the unit without discharge connected to a debris receiver box.
- Slow down and use caution when making turns and when changing directions on slopes.
- Never leave a running unit unattended. Always stop engine, and remove keys before leaving unit.
- Never operate without guards securely in place. Be sure all safety features are attached, adjusted properly and functioning properly.
- Never operate with intake or discharge components loose, removed or altered.
- Do not change the engine governor setting or over speed the engine.
- Stop on level ground, shut off engine before leaving the operator's position for any reason including emptying the receiver box or unclogging the intake or discharge.
- Stop equipment and inspect impeller blades after picking up unusually large or hard objects or abnormal vibration occurs. Make necessary repairs before resuming operations.
- Keep hands and feet away from the intake and discharge.
- Never carry passengers and keep pets and bystanders away.
- Do not operate the unit while under the influence of alcohol or drugs.
- Slow down and use caution when making turns and crossing roads and sidewalks.
- Use care when hooking or unhooking the machine to a towing vehicle.
- Use care when approaching blind corners, shrubs, trees or other objects that may obscure vision.

2 *safety rules regarding outdoor power equipment (cont.)*

SLOPE OPERATION

Slopes are a major factor related to loss-of-control and tip-over accidents, which can result in severe injury or death. All slopes require extra caution. If you cannot back up the slope, or if you feel uneasy on it, do not operate on it.

Do

- Remove obstacles such as rocks, tree limbs, etc.
- Watch for holes, ruts, or bumps. Uneven terrain could overturn the unit. Tall grass can hide obstacles.
- Use slow speed.
- Keep all movement on the slopes slow and gradual. Do not make sudden changes in speed or direction.

Do Not

- Do not start or stop on a slope. If tires lose traction, stop the unit and proceed slowly straight down the slope.
- Do not turn on slopes unless necessary, and then, turn slowly and gradually downhill, if possible.
- Do not operate near drop-offs, ditches, or embankments. The operator could lose footing or balance or unit could suddenly turn over if a wheel is over the edge of a cliff or ditch, or if an edge caves in.

CHILDREN

Tragic accidents can occur if the operator is not alert to the presence of children. Children are often attracted to the unit and its activity. Never assume that children will remain where you last saw them.

- Keep children out of the operating area and under the watchful care of another responsible adult.
- Be alert and turn unit off if children enter the area.
- Before and during reverse operation, look behind and down for small children.
- Never carry children. They may fall off and be seriously injured or interfere with safe unit operation.
- Never allow children to operate the unit.
- Use extra care when approaching blind corners, shrubs, trees, or other objects that may obscure vision.

EMISSIONS

- Engine exhaust from this product contains chemicals known, in certain quantities, to cause cancer, birth defects, or other reproductive harm.
- Look for the relevant Emissions Durability Period and Air Index information on the engine emissions label.

MAINTENANCE AND STORAGE

- Always observe safe refueling and fuel handling practices when refueling the unit after transportation or storage.
- Always follow the engine manual instructions for storage preparations before storing the unit for both short and long term periods.
- Always follow the engine manual instructions for proper start-up procedures when returning the unit to service.
- Never store the machine or fuel container inside where there is an open flame, such as in a water heater. Allow unit to cool before storing.
- Shut off fuel while storing or transporting. Do not store fuel near flames or drain indoors.
- Keep all hardware, especially impeller bolt, tight and keep all parts in good working condition. Replace all worn or damaged decals.
- Never tamper with safety devices. Check their proper operation regularly.
- Clean debris from units, drives, mufflers, and engine to prevent fires. Clean up oil or fuel spillage.
- Stop and inspect the equipment if you strike an object. Repair, if necessary, before restarting.
- Never make adjustments or repairs with the engine running unless specified otherwise.
- Park machine on level ground. Never allow untrained personnel to service machine.
- Use jack stands to support components when required.
- Carefully release pressure from components with stored energy. (e.g. springs)
- Check impeller on a regular basis for bent, worn or cracked blades. Only replace impellers; never straighten or weld them.
- Keep hands and feet away from moving parts.

2 *safety rules regarding outdoor power equipment (cont.)*

- Belts and belt guard components are subject to wear, damage, and deterioration, which could expose moving parts or allow objects to be thrown. Frequently check components and replace with manufacturer's recommended parts, when necessary.
- Check operation of brake, tail and license lights frequently. replace as required.
- Use only factory authorized replacement parts when making repairs.

- Always comply with factory specifications on all settings and adjustments.
- Only authorized service locations should be utilized for major service and repair requirements.
- Never attempt to make major repairs on this unit unless you have been properly trained. Improper service procedures can result in hazardous operation, equipment damage and voiding of manufacturer's warranty.

3 *unit assembly & set-up*

Note: Please refer to Parts List for correct part identification and placement. Parts list reference numbers are called out by sheet number followed by reference number(s) on that sheet: (1:1) indicates Sheet 1, reference number 1; (2:32,34-38) indicates Sheet 2, reference numbers 32 through 38 excluding 33; etc.

FENDER ASSEMBLY (CHW UNITS ONLY)

- Insert one 3/8-16 x 1" bolt, fitted with one 3/8" flat washer, out through the three fender mounting holes (two located in the diagonal brace, one in the support leg channel).
- Attach fenders to sides of base, making sure tail-lamp mounting brackets are toward rear of unit as shown.
- Secure each fender with flat washers, 3/8" split lock washers, and 3/8-16 hex nuts. Tighten securely.
- Install one Tail-lamp assembly into the tail-lamp mounting bracket of each fender, first by inserting the rubber grommet into the bracket hole, then pressing the tail-lamp firmly into the grommet. (Tail-lamp wiring will be addressed later.)

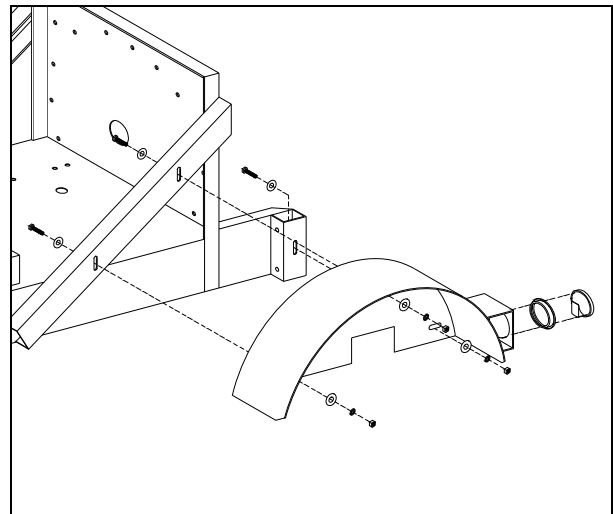

3 unit assembly & set-up (cont.)

AXLE ASSEMBLY (CHW UNITS ONLY)

Safety Note: Assistance is required when installing axle. If access to lifting equipment is possible, it is highly recommended.

- Drop one 1/2-13 x 1-1/4" bolt, fitted with one 1/2" flat washer, down through the two outermost axle mounting holes located in each of the two channels that run lengthwise under the engine base (two bolts each side, four bolts total).
- Slide axle up onto bolts, making sure axle hubs are offset toward rear of unit as shown.
- Secure assembly with four 1/2" flat washers, 1/2" split lock washers, and 1/2-13 hex end lock nuts.
- Install tires onto axle hubs with lug nuts.
- Slide Support Leg up through leg channel, hollow of leg facing out to accommodate fender bolt, and secure in uppermost position with clevis pin and bridge pin.

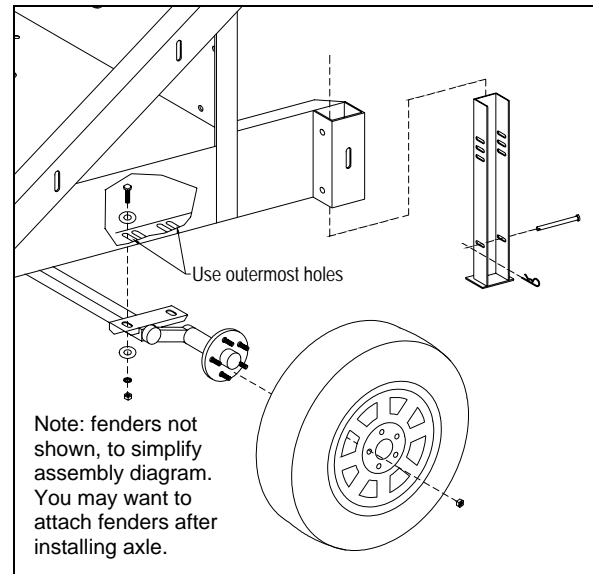

SUPPORT JACK AND SAFETY CHAIN INSTALLATION (CHW UNITS ONLY)

Safety Note: Assistance is required when installing support jack. If access to lifting equipment is possible, it is highly recommended.

- Remove jack from upside-down shipping position. Lifting draw bar, insert jack into crank assembly, making sure teeth of jack point out as shown. Crank jack up into crank assembly until unit sits level with ground, then drop support leg (installed in previous assembly step), and lock in lowermost position possible. This will prevent possible unit rollover while installing discharge assembly.
- Secure one Safety Chain onto each of the two studs on either side of the draw bar front, with one 1/2-13 reverse lock nut. Tighten snugly while allowing free movement of chain link.

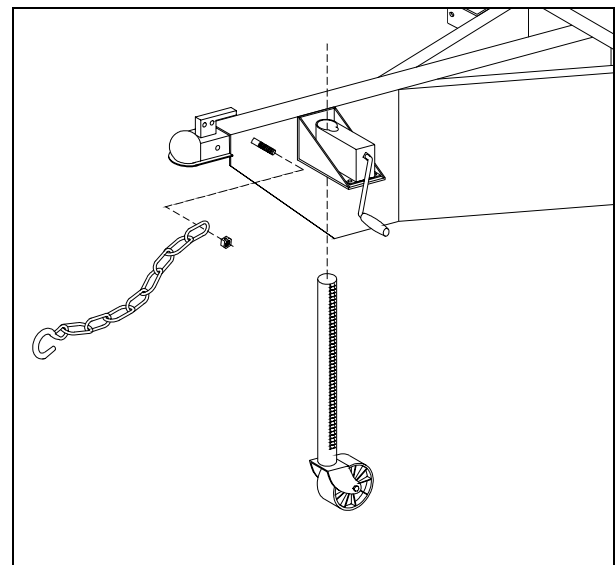

3 unit assembly & set-up (cont.)

TRAILER WIRING SCHEME (CHW UNITS ONLY)

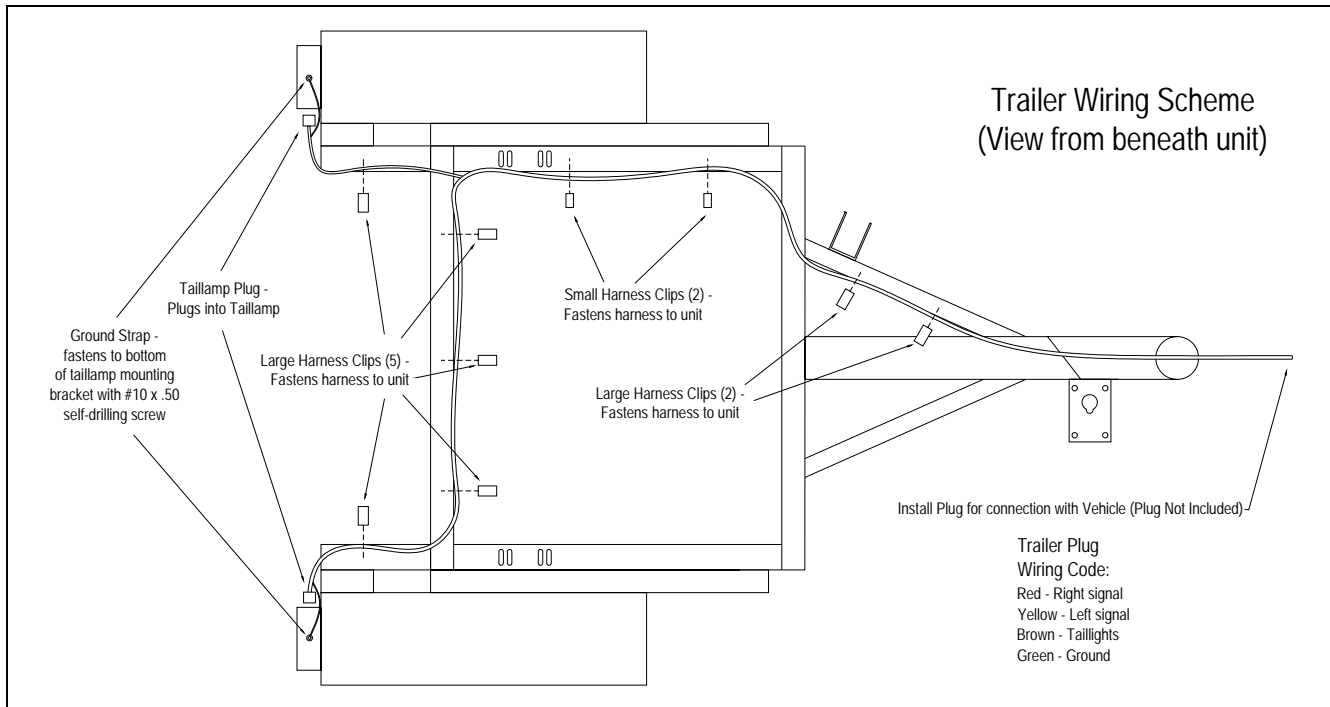

DISCHARGE ASSEMBLY (ALL UNITS)

Safety Note: Assistance is required when installing discharge stack and elbow. If access to lifting equipment is possible, it is highly recommended.



Important Safety Note: To prevent unit rollover during Discharge Assembly, lock rear support leg in lowermost position possible. Failure to do this may result in injury or death and/or damage to unit or property.

- Place discharge stack atop power unit, with boom pivot brackets facing out toward right rear of unit (from driver's perspective). Insert eight 3/8-16 x 1-1/4" hex bolts (3:2), each fitted with one flat washer (3:3), through bolt flange holes, securing with flat washers, lock washers and nuts (3:3-5). Tighten securely.
- Attach discharge elbow (3:1) to top of stack, with discharge directed toward towing hitch, using same hardware as in above step. Tighten securely.

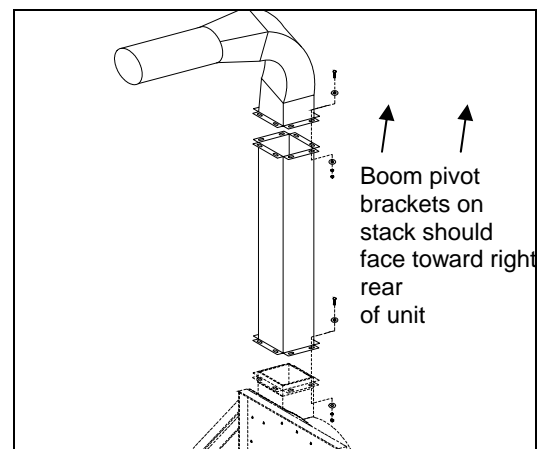

3 *unit assembly & set-up (cont.)*

- Slip one end of metal discharge hose (3:6) onto barrel of discharge stack.
- Secure hose in place with squeeze ring (3:7), tightening all bolts securely enough to dimple hose against barrel of stack and thereby prevent slippage of hose on stack assembly.

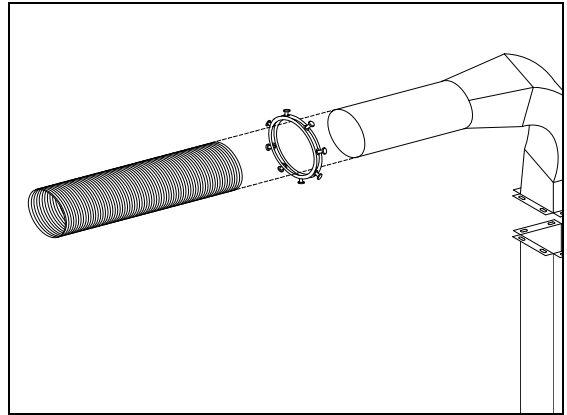

INTAKE ASSEMBLY (ALL UNITS)

- Slip one hose clamp (2:9) onto one end of intake hose (2:8), then slip end of hose onto intake flange barrel (2:5), located in front of impeller housing. Tighten clamps securely.
- Slip Hose support band (2:10) about half-way up the length of the hose, with eye clip facing up.
- Slip one hose clamp onto free end of intake hose, followed by Intake Nozzle (2:11) with handle pointed upwards and toward hose. Tighten clamps securely.

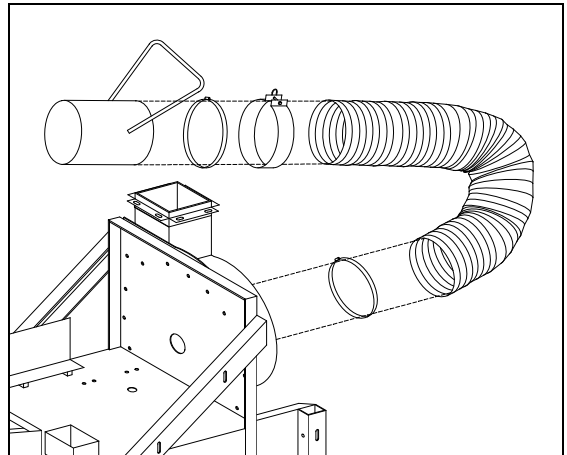

BATTERY SERVICE AND CONNECTIONS

- Fill battery with acid (auto parts store).
- Connect battery cables (hardware not supplied), making careful note of polarity:
 - Long cable from engine goes to battery positive (+)
 - Short cable bolted to engine base next to battery box goes to battery ground (-)
- Slip terminal covers on cables over battery terminals



Important Safety Note: Incorrect battery cable connection can result in personal injury or equipment damage.

3 *unit assembly & set-up (cont.)*

DEBRIS BOX CONSTRUCTION



WARNING: This unit is designed to be used in conjunction with a debris collection box. NEVER run or operate your Truck Loader without a debris box.

Below are directions for constructing a simple, sturdy debris box for use in a standard pickup bed:

- Cut four pieces of 3" angle iron to the inside length of the truck bed, four pieces to the inside width, then four pieces that measure from the truck bed floor to approximately 8" higher than the top of the unit discharge when the unit is connected to the truck. Either weld or securely bolt the box frame together.
- Line the inside front and sides with 3/4" exterior grade plywood.
- Cover the top of the frame with a heavy duty mesh screening to allow for adequate ventilation.
- Cut a plywood door the width and height of the box frame. Install a heavy duty hinge at the top of the door and fasten it to the rear of the box frame. Install latches or other locking mechanisms between the lower sides of the door and the box sides to keep the door from opening inadvertently.
- Mark the location on the door where the unit discharge meets the box, then cut a 16" diameter hole in the door at that location. Install a rubber gasket around the hole to prevent debris blow-by – an old 13" or 14" inner tube works fine.

CONNECTING UNIT TO TOWING VEHICLE

- Install appropriate trailer plug onto end of unit wiring harness to match socket on towing vehicle. Wiring scheme is as follows:

Red – Right signal
Yellow – Left signal
Brown – Taillights
Green – Ground

- Back towing vehicle up to unit. Raise or lower support jack until ball hitch receiver on unit is about 3-4" higher than ball hitch on vehicle. Flip lock lever up on ball hitch receiver.
- With assistance behind, back up slowly, aligning both ball hitch receiver with ball hitch and discharge hose with receiver box opening.
- Lower front of unit down until ball hitch receiver drops completely onto ball hitch. Rock unit back and forth a couple of times to ensure full coupling of ball hitch. Lock ball hitch receiver lever. Use a clevis pin or padlock through locking hole in lever, to prevent accidental disconnect.
- Connect safety chains to vehicle in a criss-cross fashion to cradle draw bar in case of accidental disconnect, then connect wiring harness plug into trailer socket of vehicle.
- Lift rear support leg and secure in uppermost position with clevis pin. Also be sure to fully raise support jack.



Note: To prevent possible rollover, lock rear support leg in lowermost position possible when unit is parked or disconnected from towing vehicle.

Your unit is now ready to be started and checked for proper operation. See your engine manual for proper engine prep and operation.

4 *unit operation*

GENERAL GUIDELINES TO OBSERVE DURING OPERATION

- Never allow a person to ride, sit or stand on the unit. Never allow a person to ride, sit or stand on the towing vehicle other than in the driver's cab of the towing vehicle.
- Make sure that the driver of the towing vehicle has the operator of the unit in full view at all times. Also, when operating the unit, instruct the operator to stay to the side of the machine, never in front or behind.
- Collecting debris into piles for the machine to intercept prior to startup will save time and fuel as well as wear and tear on the unit.
- We recommend the following for the most efficient performance: if debris is very dry, run the machine at approximately half throttle; this will help reduce the amount of small particles of debris escaping through the ventilation screen. If debris is wet or partially frozen, run the machine at full throttle.
- Lower intake hose boom assembly until nozzle floats 2-3 inches from the ground, then adjust engine throttle so that when nozzle is pushed to the ground, suction can be broken with moderate effort using three fingers of one hand. This will make operation relatively easy and comfortable.
- Time and experience will be your best guide in finding the most efficient performance from your unit.

UNCOUPLING UNIT FROM TOWING VEHICLE

- Disconnect taillight/brakelight plug from towing vehicle receiver.
- Unhook safety chains from rear of towing vehicle.
- Unlock ball hitch receiver lever on unit and flip lever up.
- Crank down wheel jack until ball hitch receiver on unit clears ball hitch on towing vehicle.
- Drop rear support leg to lowermost position and secure with clevis and bridge pin. **Note: Failure to follow this step can result in unit rollover and serious personal injury and unit damage.**
- Pull vehicle away from unit.

5 *unit maintenance*

GENERAL MAINTENANCE

NOTE: Some maintenance services, such as engine repairs, electrical repairs, etc., should be performed only by a qualified technician.

- Check overall condition of unit prior to each use, repairing or replacing worn, damaged or missing components promptly. Check all fasteners regularly and tighten if necessary.
- Follow engine manufacturer's recommendations for maintenance schedules. Use only recommended parts, fluids and lubricants. Failure to follow manufacturer's recommendations may void manufacturer's warranties.
- Lubricate impeller shaft bearings every 50 hours of operation. Use a high quality bearing grease, available from your local dealer (or auto parts store).
- Maintain tire pressure as indicated on tire sidewall. Replace worn or damaged tires promptly.
- Keep engine free from a buildup of grass, leaves or excessive grease. An accumulation of these combustible materials may result in a fire, or simply impede performance.
- Never change attachments or make any adjustments, repairs or replacements until the unit is completely shut down and the battery is disconnected.

STORAGE

- Keep the unit in locked storage to prevent unauthorized individuals, especially children, from playing and/or tampering with the unit.
- When storing the unit for prolonged periods, it is recommended to disconnect the battery.
- Store fuel in an approved, clearly marked container.
- NO NOT store gasoline powered equipment or fuel containers in any closed area where heat-radiating appliances or open pilot lights are present, unless the fuel has been completely drained from the power equipment and the fuel containers.

REPLACEMENT PARTS

Replacement parts are available from your local Giant-Vac dealer.

warranty

GIANT-VAC, INC., here-in-after called Giant-Vac, warrants each new Giant-Vac to the original retail purchaser of the new Giant-Vac equipment to be free from manufacturing defects in normal service for a period of 1 year, unless it is used for rental purposes, which limits the warranty to 30 days. This warranty does not apply to engines, tires or other parts that are purchased and warranted by their manufacturer. Items such as bags, grass catchers, hoses and blades are not warranted, as these are considered expendable items. This warranty does not include equipment failures due to normal wear.

Any obligation under this warranty is expressly limited to the replacement or repair, at an authorized servicing Giant-Vac dealer, or at a point designated by us, of such parts as appear to us to have been defective. All defective parts have to be returned freight prepaid before credit will be issued.

We shall not be liable for transportation charges in connection with the replacement or repair of defective parts.

This warranty does not apply to a Giant-Vac upon which repairs or alterations have been made by others except with our prior written approval.

We shall not be liable for consequential damages or contingent liabilities for the fitness of any Giant-Vac for any particular purpose.

We make no other express, implied or statutory warranty, nor is anyone authorized to make any in our behalf.

GIANT-VAC[®]

535 Macon Street
McDonough, GA 30253
PHONE: 866-792-8223

Giant-Vac Models TLP29201BVG

Sheet 1 - ENGINE GROUP

<u>REF. NO.</u>	<u>PART NO.</u>	<u>DESCRIPTION</u>	<u>TLP29201BVG</u>
1	10266	Engine Base & Trailer Frame CHW	1
2	39044	29HP Briggs & Stratton Engine	1
--	39129	Muffler Deflector (w/hardware CHW Units Only)	1
--	39187	Muffler Guard	1
--	39224	Exhaust Deflector	1
--	32229	Hex Bolt 6mm x 25mm	1
--	32230	Flat Washer 6mm	2
3	31747	3/8 x 2" Hex Bolt (Motor Mount Bolt)	3
3	31595	3/8 x 1-3/4" Hex Bolt (Motor Mount Bolt)	1
4	31008	3/8 Lock Washer	4
5	31009	3/8 Hex Nut	4
6	21517	Impeller	1
7	31447	5/8-18 x 2" Impeller Bolt & Key Group	1
8	40117	Fuel Tank	1
8A	31755	Hose, Rubber Fuel 1/4" x 10" Length	1
--	34041	Clamp, Hose 1/4" Worm Drive	4
--	32117	Clamp, 3/8	3
9	31157	Fuel Tank Strap	2
9A	31158	Gas Tank Mount	1
9B	31445	Inline Fuel Shutoff Valve	1
10	40119	Fuel Tank Cap	1
11	39020	Battery	1
11A	40118	Battery Box	1
12	31642	Battery Cable - 32SS (Positive)	1
--	31836	Battery Terminal Cover - Red	1
13	31643	Battery Cable - 16SS (Ground)	1
--	31837	Battery Terminal Cover - Black	1
14	31009	3/8 Hex Nut (secures ground cable to engine base)	1
15	31008	3/8 Lock Washer	1

GIANT-VAC, INC.
Model TLP29201BVG
Engine Group
Sheet 1 of 4
R0307.1

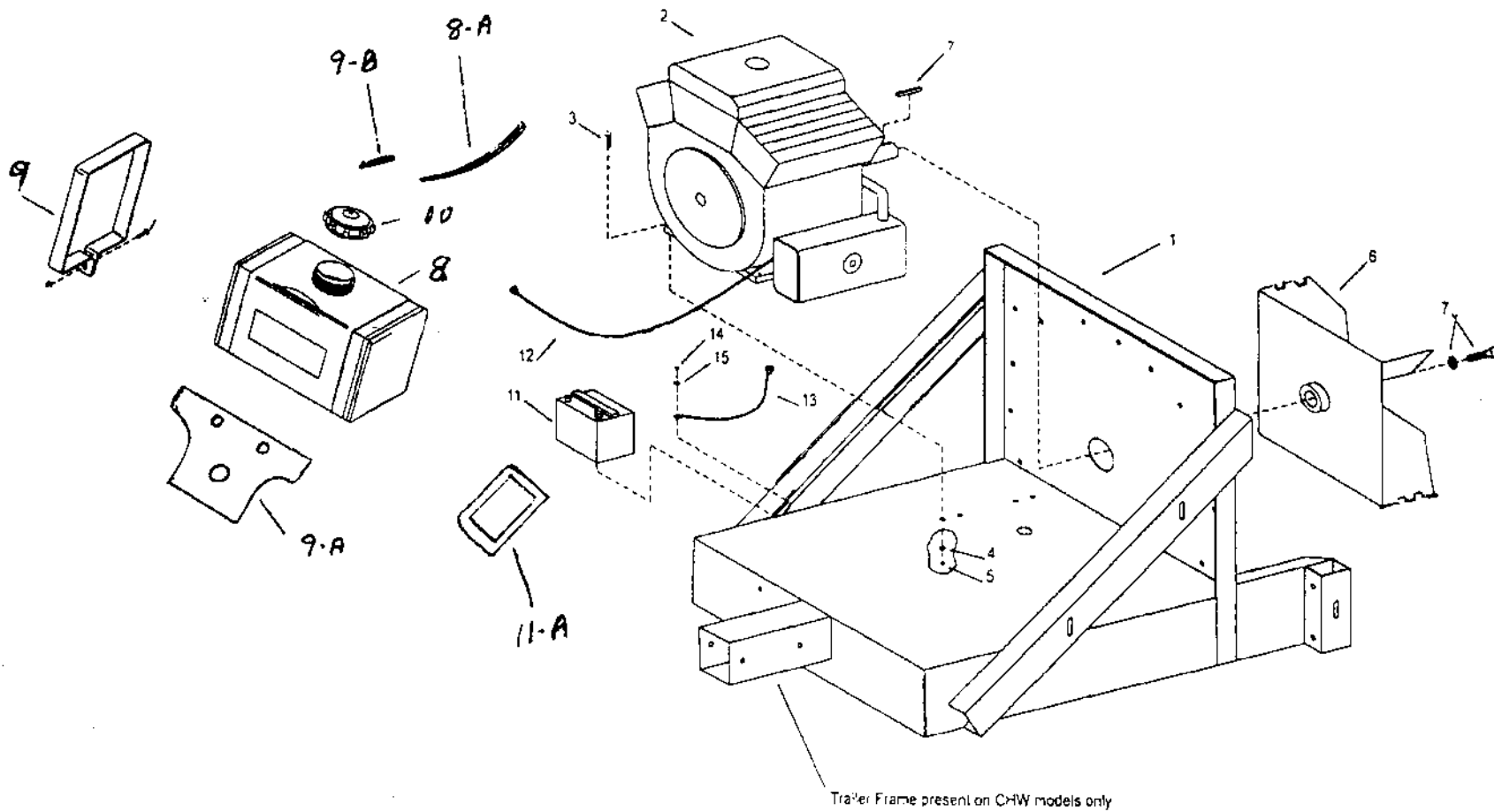

Giant-Vac Models TLP29201BVG
Sheet 2 - INTAKE GROUP

<u>REF. NO.</u>	<u>PART NO.</u>	<u>DESCRIPTION</u>	<u>TLP29201BVG</u>
1	10272	Housing, Impeller	1
2	31033	3/8-16 x 1" Hex Bolt	18
3	31008	3/8 Lock Washer	18
4	31009	3/8-16 Hex Nut	18
5	34019	Hose, Intake 12" x 10'	1
6	34020	Clamp, Hose 12"	2
8	20156	Nozzle, Intake 12"	1
9	27268	Plate, Hose Protector (CHW Units Only)	1

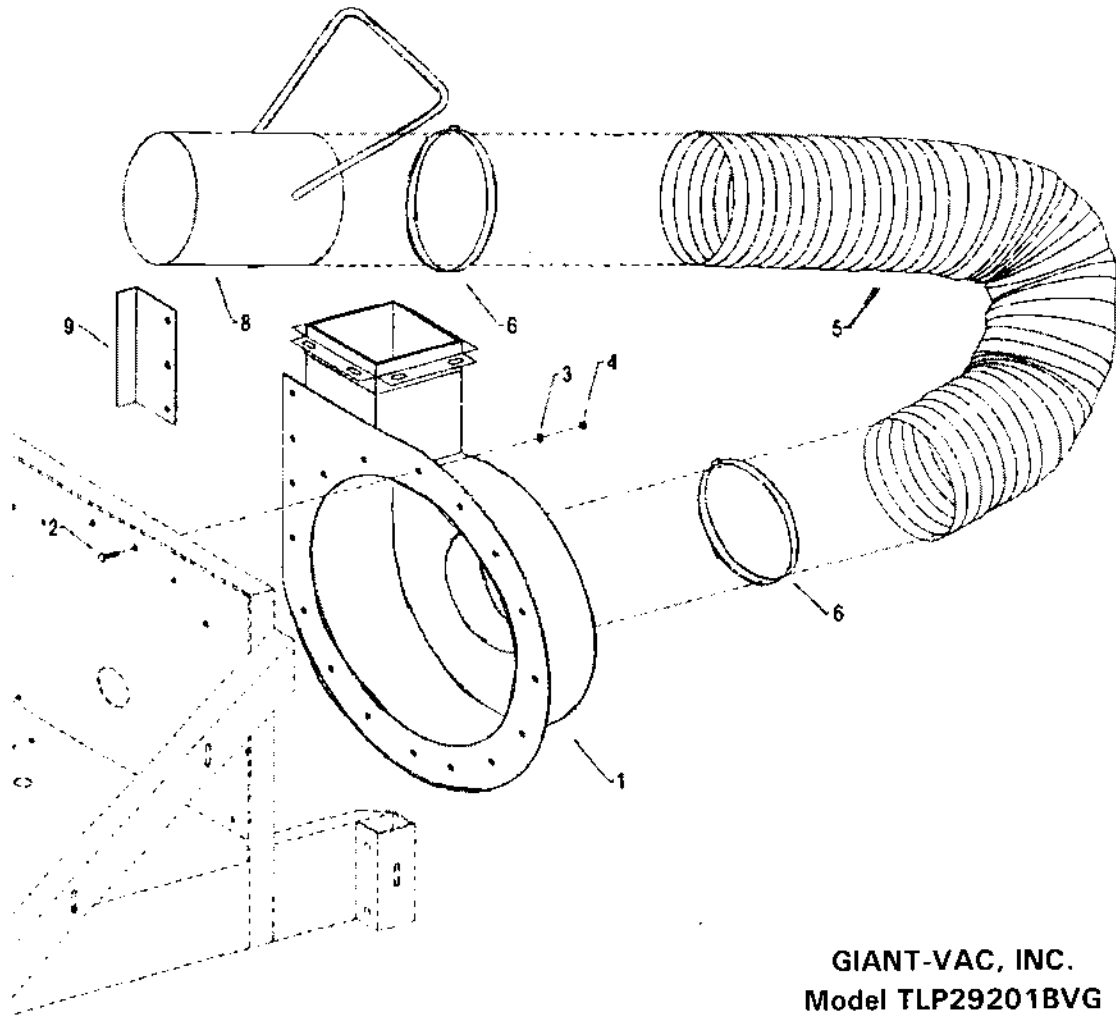

GIANT-VAC, INC.
Model TLP29201BVG
Intake Group
Sheet 2 of 4
R0307.1

Giant-Vac Models TLP29201BVG
Sheet 3 - DISCHARGE GROUP

<u>REF. NO.</u>	<u>PART NO.</u>	<u>DESCRIPTION</u>	<u>TLP29201BVG</u>
1	24640	Discharge Stack	1
2	24641	Discharge Elbow	1
3	31097	3/8-16 x 1-1/4" Hex Bolt	16
4	31034	3/8 Flat Washer	32
5	31008	3/8 Lock Washer	16
6	31009	3/8-16 Hex Nut	16
7	34021	Hose, Discharge 8" x 5' Metal	1
8	34048	Ring, Squeeze 8"	1
--	31086	1/2-13 x 1-3/4 Bolt	1

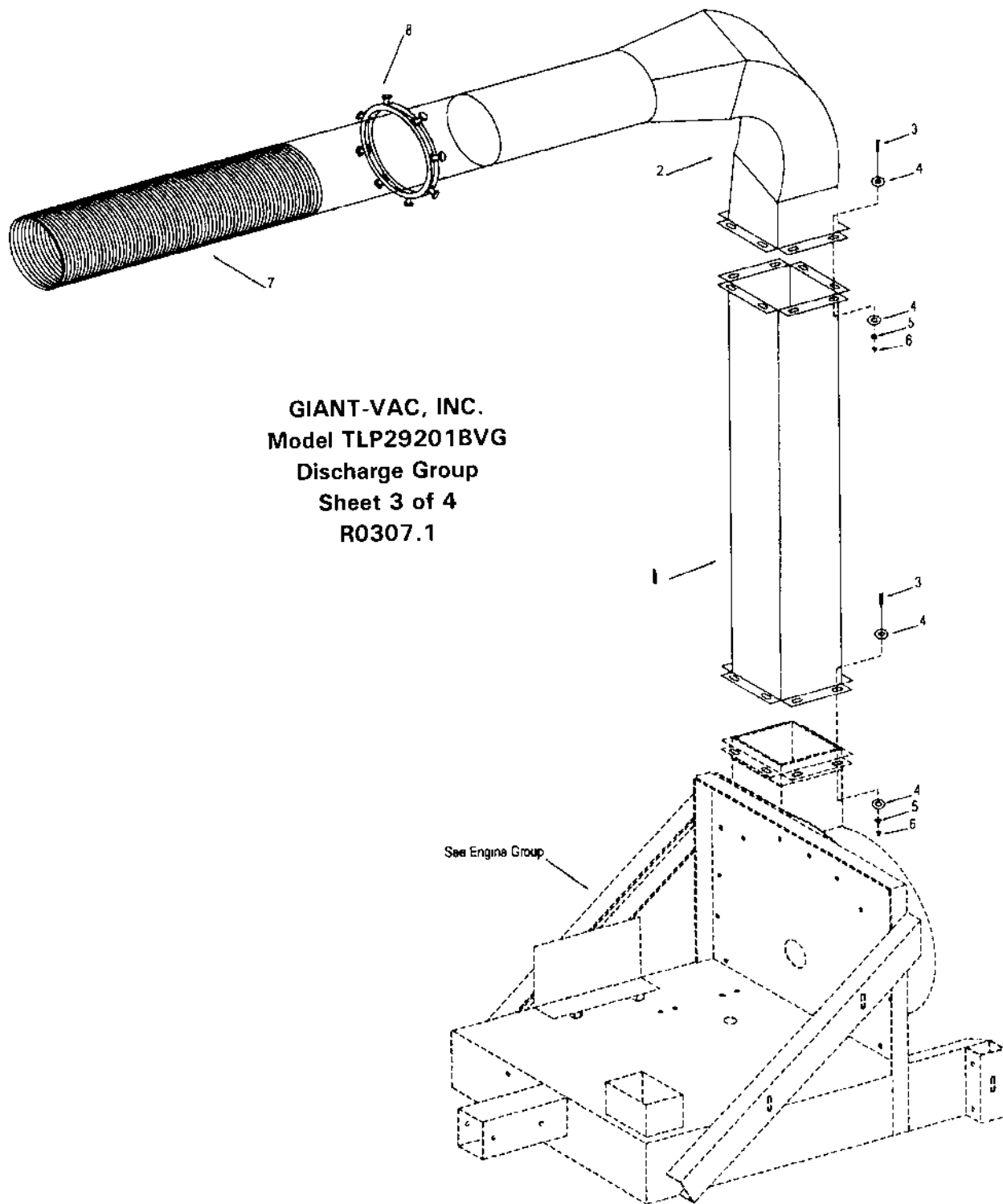

GIANT-VAC, INC.
Model TLP29201BVG
Discharge Group
Sheet 3 of 4
R0307.1

Giant-Vac Models TLP29201BVG
Sheet 4 - TRAILER GROUP (CHW UNITS ONLY)

<u>REF. NO.</u>	<u>PART NO.</u>	<u>DESCRIPTION</u>	<u>TLP29201BVG</u>
1	33334	Axle 2,000 lbs	1
1a	33182	Axle Bolt Plate	2
1b	33183	Axle Reinforcement Plate	2
1c	31078	1/2 Lock Washer	4
1d	31637	1/2 Nylon Lock Nut	4
6	33051	F78 x 15 Tire and Wheel Assembly	2
7	31152	1/2-20 Lug Nut	10
8	33336	Fender - Left Side	1
8	33335	Fender - Right Side (Not Shown)	1
9	31033	3/8-16 x 1" Hex Bolt	6
10	31034	3/8 Flat Washer	12
11	31008	3/8 Lock Washer	6
12	31009	3/8-16 Hex Nut	6
13	31639	Tail Lamp (w/Rubber Mounting Ring)	2
--	31640	Tail Lamp Wiring Harness	1
--	31644	Wiring Harness Bold Clip - Large	7
--	31823	Wiring Harness Bold Clip - Small	2
--	32090	#10 x 1/2" Self-Tapping Screw (Fastens Grounds)	2
14	40126	Support Leg	1
15	31125	3/8 x 4" Clevis Pin	1
16	31126	Bridge Pin	1
17	38044	Draw Bar - Swing Jack Style	1
18	31017	5/8 x 4-1/2" Hex Bolt	4
19	31326	5/8 Split Lock Washer	4
20	31199	5/8 Lock Nut	1
21	33176	Jack, Trailer Support Swing Away Style	2
--	31033	3/8-16 x 1" Hex Bolt	4
--	31008	3/8 Lock Washer	4
--	31009	3/8-16 Hex Nut	4
22	31495	3/8-16 x 5" Hex Bolt	2
23	31108	3/8 Split Lock Washer	1
24	31126	Bridge Pin	1
25	31641	Chain, Safety w/1 S-Hook	1
26	31047	1/2-13 x 5" Hex Bolt	1
27	38014	Ball Hitch Mount, Black	1
28	38011	Ball Hitch	1
29	31467	1/2-13 x 3-1/2" Hex Bolt	1
30	31078	1/2 Lock Washer	1
31	31406	1/2 Lock Nut	1
32	38012	Pintle Ring (Optional)	1
36	31671	Chain, Nozzle Retainer 1/2 x 12"	1
37	31495	3/8-16 x 5" Hex Bolt	1

GIANT-VAC, INC.
Model TLP29201BVG
Trailer Group
Sheet 4 of 4
R0307.1

