

GIANT-VAC MFG., INCORPORATED
SOUTH WINDHAM, CT 06226
860-423-7741

THE BIG-GIANT LOG SPLITTER

2405-B 2405-BSA 2405-BHW 2405-BHWSA 2425-BHWSA

Your Big-Giant Log Splitter comes complete in two crates--Models 2405-B and 2405-BHW, three crates - with the necessary parts. Inspect your unit for any damage that might have occurred in shipping. If any is found, save the packing container and immediately notify the Transport Carrier who delivered your machine as he is responsible for the damage and is the only one to make any adjustments. Before leaving our plant, all components are completely inspected. All manufacturing dimensions are held to close tolerances, and thus you will have little difficulty in assembling your Log Splitter if you follow these steps.

CALIFORNIA PROPOSITION 65 WARNING

Gasoline and Diesel engine exhaust and some of its constituents are known to the State of California to cause cancer, birth defects and other reproductive harm.

As an owner of off-road gasoline or diesel engine equipment and/or as an employer, you also may have an obligation under the California Occupational Safety and Health Act or under Proposition 65 to warn persons exposed to gas and diesel engine exhaust and/or other Proposition 65 chemicals in and around your workplace. See California Health and Safety Code section 25249.5, Title 22 of the California Code of Regulations at Section 1200 *et seq.*, and Title 8 of the California Code of Regulations Section 5194.

MOTOR INSTRUCTIONS:

You have received a complete engine manual with your machine. Especially note instructions on OILING. Fill out the Warranty Card immediately and send it to the engine manufacturer and not to Giant-Vac. Consequently, if any difficulties exist, please contact them rather than us as much time will be saved as they are the only ones to make any adjustments. If you will check the yellow pages in your telephone book, you will find the local engine servicing dealer.

1. Install wheels on motor base with two 5/8" x 3 1/2" bolts and lock nuts. To tighten wheel securely, tighten lock nut onto wheels on Model 2405-BHW only. Place axle under motor base and install with four 1/2 x 2" bolts, nut & lockwasher. Next, install wheels on axle,

then securely install the 2" ball hitch and hitch holder on the front of the main frame.

Caution: wheel bearing must be serviced with wheel bearing grease before installing. Do not over tighten the lock nut onto the side of the wheel bearing.

2. Install main frame onto motor base with four ½" x 2" bolts. Make sure flat washers and lock washers are used on slotted holes.
3. Install hydraulic pump onto motor base. First put pump shaft through center hold, then install the pump half of the coupling with an 1/8" keyway. Do not tighten at this time. Install motor end of coupling with rubber spider and using ¼" keyway. Then install the pump with two 5/16" bolts and lock nuts. (Make sure street elbow on pump is facing upward). (We recommend type sealer Teflon on all pipe thread fittings). Then install low pressure hose from pump to main frame. This would be the hole closest to the wedge on the main frame.
4. Install valve body onto motor base upright. (Make sure the valve handle is facing towards wedge). With three 2" x 5/16" bolts, nuts and lockwashers. Next, install high pressure hose from pump to cylinder side of valve. Then install the two top hoses from valve to cylinder. The short hose goes to the front part of cylinder and long hose goes to the back part of cylinder, then install the other low pressure hose, again using Teflon pipe sealer onto main frame. This hole is located near the motor base. Next install valve handle.
5. Install ram head onto cylinder rod using the 1 ¼" pins supplied and using the ½" bolts with lock washers and flat washer supplied. Make sure to use flat washers to hold pins in place. Then slide the four ½" bolts through ram head and install the two bottom spacers and then the bottom plate and securely lock with ½" nuts and lock washers supplied. Make sure ram head is installed on center of top plate.
6. CAUTION: Before starting engine. The hydraulic pump can be damaged if run before the hydraulic system has been serviced.
7. Please follow the engine manual for type of oil and grade of gasoline to be used.
8. Do not run engine until hydraulic system has been serviced with 14 quarts of Quaker State Dextron 2 or equivalent type automatic transmission fluid.

OPERATING INSTRUCTIONS

CYCLING RAM: Cycle the ram 15 to 20 full strokes to eliminate any trapped air in the hydraulic system. If the ram seems to lunge or moves in surges, some air is still trapped in the system. Continue to cycle the ram through the full stroke until a steady forward and return stroke is obtained.

OPERATING LEVER: Ram movement forward, neutral and reverse is completely controlled by the lever. Pushing the lever forward or towards the wedge will cause the ram to move forward. When the lever is in the center, the ram will not move. Pull the lever for reverse. The lever may be pushed into forward or into reverse at any time during the forward or return stroke.

LOG SIZE: Your Big-Giant Log Splitter provides over 10 ton ram pressure and is designed to split most wood 24 inches long by 18 inches in diameter. To split large, tough logs, always place the log on the splitter so as to split first, a side section. Continue to slab split the large log until a medium sized piece remains, then split it down the center.

MAINTENANCE:

- A. Please follow your Engine Manual on type of oil and when to change it.
- B. The oil and oil filter in the hydraulic system should be changed every 80 hours of operation under normal conditions, and more frequently under dusty conditions. To change the oil in the hydraulic system, the RAM should be in returned position, then simply remove the plug located under the FRAME. Refill with 14 quarts of Quaker State Dextron 2 or equivalent after replacing plug on bottom of frame. To check oil level, run the RAM out all the way and there should be two (2) inches oil level in the oil tank.
- C. Keep the top platen where the log and ram travel free from oil and dirt. The guide shoes under the ram will last longer. Dirt mixed with oil acts as an abrasive compound and quickly wears down the ram shoes and top platen.

CHECK ALIGNMENT BEFORE STARTING PUMP

The single common cause of pump failure on start up (AND IS NOT WARRANTED) is failure to correctly mount the flexible coupling on the pump shaft end and/or misaligning the pump/coupling/motor or engine drive.

1. Don't force or pound the pump coupling half over the pump shaft. End thrust could damage the pump internally.
2. The flexible coupling is not a universal joint. Coupling shaft misalignment acts directly on the shaft seal, shaft bearing, and precision-fitted internal parts. Before the initial start up and after mounting pump and piping is complete, take enough time for a final check with a straight edge that the coupling halves are not parallel or angular misaligned (see sketch) or too close and introducing an end thrust to the pump.

SOME MORE CAUTIONS

If you use Teflon tape on your fittings, use only 1½ wraps and none on the first two threads. Special care should be taken to avoid over-tightening pipe connections. Due to the excellent lubricity of the Teflon tape the wrench tightening "feel" is different than when the fitting is dry or pipe doped. You can screw a fitting in and crack the port or distort the casting without getting a "snugged up" feel. A good rule of thumb is to turn the connector (Example 3/8 NPTF steel tubing fitting) in about 2½ turns by hand then 1½ turns by wrench into a 3/8 NPTF tapped port hole in cast iron. Remember it is usually easier and cheaper to snug up a leaking joint than to replace a component.

Starting the hydraulic pump properly for the first time can save you trouble of a quick failure. Jog the pump several times (alternately start and stop unit) until pump is primed and full flow begins.

Use the recommended CLEAN oil. If pump is noisy it may be an indication of a starving pump, an air leak in the inlet line fittings, too thick oil, or a clogged inlet filter.

If the pump is equipped with an internal relief valve, the pump should not be operated at pressures greater than 80% of the full by-pass setting (i.e., 80% of 2000 PSI = 1600 PSI). Otherwise, it will recirculate hot oil internally overheating the pump and thinning the oil and eventually fail the pump.

GIANT-VAC WARRANTY

GIANT-VAC MFG. INCORPORATED, here-in-after called Giant-Vac, warrants each new Giant-Vac to the original retail purchaser of the new Giant-Vac equipment to be free from manufacturing defects in normal service for a period of 90 days, unless it is used for rental purposes, which limits the warranty to 30 days. This warranty does not apply to engines, tires or other parts that are purchased and warranted by their manufacturer. Items such as bags, grass catchers, hoses and blades are not warranted, as these are considered expendable items. This warranty does not include equipment failures due to normal wear.

Any obligation under this warranty is expressly limited to the replacement or repair, at an authorized servicing Giant-Vac dealer, or at a point designated by us, of such parts as appear to us to have been defective. All defective parts have to be returned freight prepaid before credit will be issued.

We shall not be liable for transportation charges in connection with the replacement or repair of defective parts.

This warranty does not apply to a Giant-Vac upon which repairs or alterations have been made by others except with our prior written approval.

We shall not be liable for consequential damages or contingent liabilities for the fitness of any Giant-Vac for any particular purpose.

We make no other express, implied or statutory warranty, nor is anyone authorized to make any in our behalf.

GIANT-VAC MFG. INCORPORATED
P.O. BOX 195
SOUTH WINDHAM, CT. 06266
PHONE: 860-423-7741 FAX: 860-423-2654

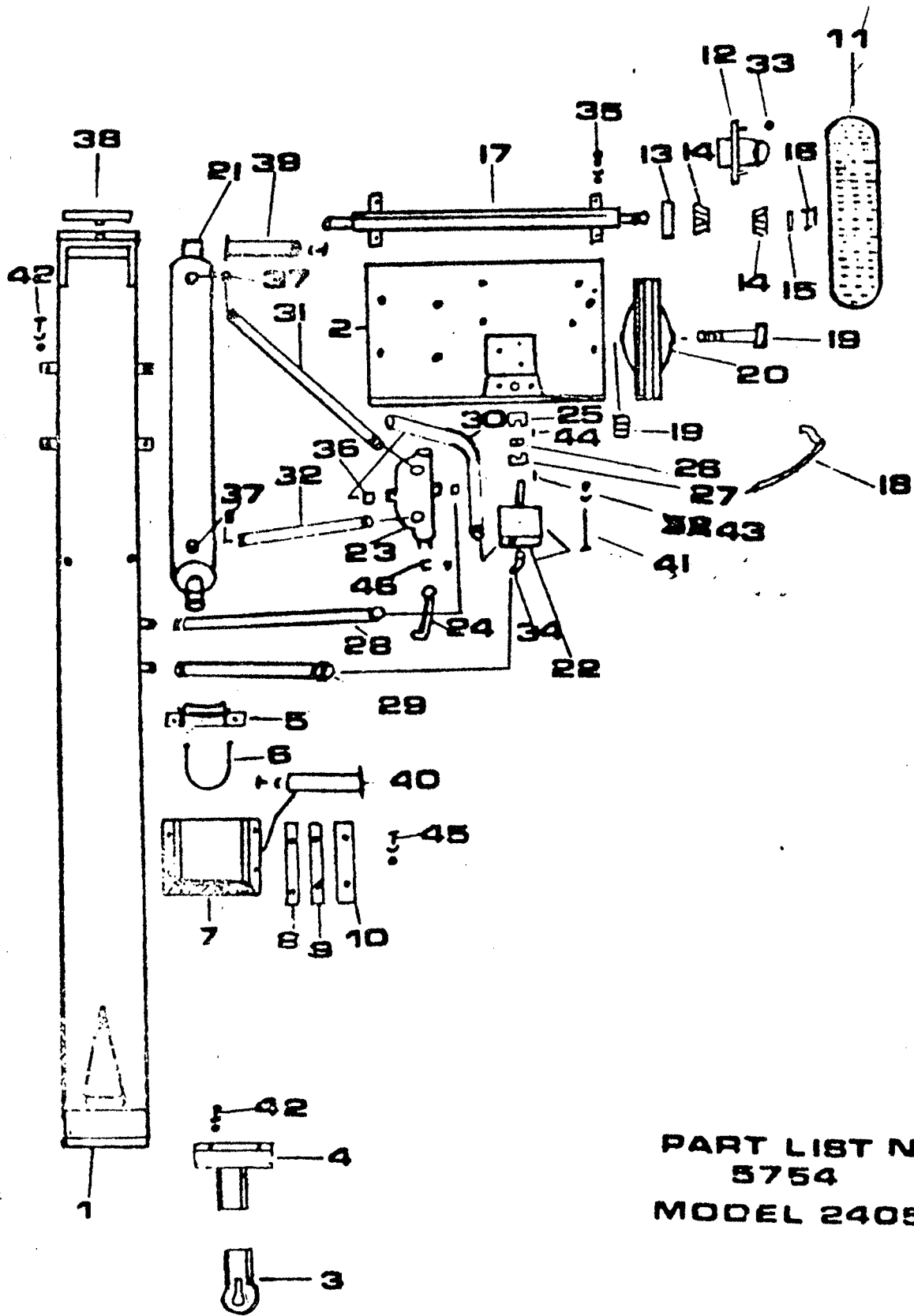

PART LIST NO.
 5754
 MODEL 2405

Parts List No. 5754

Ref No	Part No	Description	2405-B	2405-BSA	2405-BHW	2405-BHWSA	2425-BHWS
1	10071	Main Frame	1	1	1	1	1
2	10072	Motor Base	1	1	1	1	1
3	38013	Ball Hitch 2"			1	1	1
4	38014	Hitch Holder			1	1	1
5	27126	Bottom Cylinder Support	1	1	1	1	1
6	27127	Top Cylinder Support	1	1	1	1	1
7	27128	Ram Head	1	1	1	1	1
8	27129	Upper Ram Head Spacer	2	2	2	2	2
9	27130	Spacer Ram Head	2	2	2	2	2
10	27131	Bottom Ram Head Spacer	2	2	2	2	2
11	33037	Wheel 16" O.D.			2	2	2
12	33058	Hub			2	2	2
13	33057	Seal			2	2	2
14	33056	Bearing-High Speed			4	4	4
15	31151	Axle Nut			2	2	2
16	33055	Dust Cap			2	2	2
17	33086	Axle High Speed			1	1	1
18	35000	Throttle Cable	1	1	1	1	1
19	31261	Axle Bolt & Locknut, 5/8" x 4"	2	2			
20	33087	Wheel Semi-Pneumatic	2	2			
21	61017	Cylinder 24" x 4"	1	1	1	1	1
22	61018	Pump	1	1	1	1	
22	61032	Pump					1
23	61019	Valve	1		1		
23	61030	Valve Semi-Automatic		1		1	1
24	23074	Valve Control Lever	1	1	1	1	1
25	31262	Coupling Engine Half	1	1	1	1	1
26	31263	Insert Spider	1	1	1	1	1
27	31264	Coupling Pump Half	1	1	1	1	1
28	61020	Low Pressure Hose 1/2" x 28"	1	1	1	1	1
29	61021	Low Pressure Hose 1/2" x 13"	1	1	1	1	1
30	61022	High Pressure Hose 3/8" x 22"	1	1	1	1	1
31	61023	High Pressure Hose 3/8" x 24"	1	1	1	1	1
32	61024	High Pressure Hose 3/8" x 13"	1	1	1	1	1
33	31152	Lug Nut			8	8	8
34	63026	Street Elbow 1/2"	1	1	1	1	1
35	31185	Bolt, Nut, Washer 3/8" x 1 1/4"			4	4	4
36	61028	Connector 3/4" x 1 1/2"	2	2	2	2	2
37	61029	Connector 1/2" x 3/8"	2	2	2	2	2
38	61031	Filler Cap	1	1	1	1	1
39	31265	Back Ram Pin	1	1	1	1	1

Parts No. 5754

Ref No	Part No	Description	2405-B	2405-BSA	2405- BHW	2405- BHWSA	2425- BHWS
40	31266	Front Ram Pin	1	1	1	1	1
41	31267	Bolt, Nut 5/16" x 1½"	2	2	2	2	2
42	31268	Bolt, nut, washer ½" x 2¼"	4	4	12	12	12
43	31277	Key Pump Shaft	1	1	1	1	1
44	31278	Key Motor Shaft	1	1	1	1	1
45	31270	Bolt, nut washer ½" x 2½"	4	4	4	4	4
46	31271	Valve Lever Holder	1	1	1	1	1
	39001	5 HP B&S Engine	1	1	1	1	1